

P911-1A – FAST HEIGHT ADJUSTMENT PIN

Sales & Service

Spieth Anderson International, Inc.
Forestview Road, P.O. Box 40
Orillia, Ontario
Canada L3V 6H9
Telephone: (705) 325-2274
Fax: (705) 325-1485

Toll Free: (800) 563-6479

Spieth Anderson U.S.A. Inc.
4608-A Fairlane Avenue
Fort Worth, Texas
USA 76119
Telephone: (817) 536-3366
Fax: (817) 536-3006

Toll Free: (800) 331-8068

Please read the following instructions carefully before installing your P911-1A Fast Height Adjustment Pin.

P911-1A - Instruction #8920007
November 10, 2006

www.spiethanderson.com

About the P911-1A Fast Height Adjustment Pin

The **P911-1A** Fast Height Adjustment Pin is supplied as a package that includes all the parts required for replacing a lost or damaged Fast Height Adjustment Pin on your Spieth Anderson **121WR / 121PB** Uneven Bars.



- Only qualified persons should undertake the installation of Fast Height Adjustment Pins.
- Cable Tension must be released, the fibreglass rails removed and the Adjusting Tube Assemblies slid out of the Uprights before the Fast Height Adjustment Pin(s) can be replaced.
- Determine the version of **Fast Height Adjustment Pin Stop Sleeve** you have, does it have a **Locking Pin** or **Locking Set Screw** (see FIG 1)?

Installation Instructions

1. Remove the damaged Fast Height Adjustment Pin from the Upright. If the Fast Height Adjustment Pin is already removed, ensure that the old **Locking Pin** or **Set Screw** has also been completely removed (see FIG. 1).
 - (a) Pull the damaged Fast Height Adjustment Pin to the “out” position.
 - (b) • Locking Pin version - Use a punch to tap the old Locking Pin through the Stop Sleeve.
• Set Screw version - Use an Allen Key to remove the old set screw from the Stop Sleeve.
This will allow the damaged Fast Height Adjustment pin to be removed from the Upright.
2. Install the new Fast Height Adjustment Pin by proceeding as follows:
 - (a) Push the new Fast Height Adjustment Pin fully into the Upright Tube through the Stop Sleeve. Ensure that the groove in the Fast Height Adjustment Pin aligns with the **Locking Pin / Setscrew** hole in the Stop Sleeve as shown in FIG. 1.
 - (b) Tap the New Locking Pin or screw the new setscrew into the Stop Sleeve (see FIG 1.)
3. Work the newly installed Fast Height Adjustment Pin to ensure that the **Locking Pin / Setscrew** is properly installed. The **Locking Pin / Setscrew** should allow the Fast Height Adjustment Pin to move smoothly while preventing it from coming completely out of the Stop Sleeve.

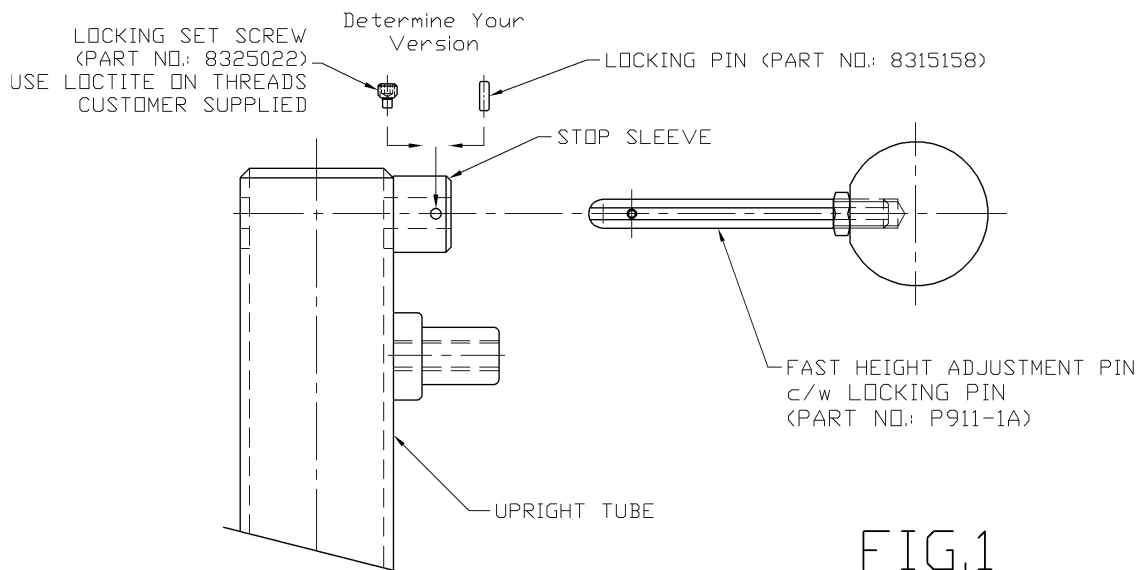

FIG.1